

# Coaxial Speaker Unit

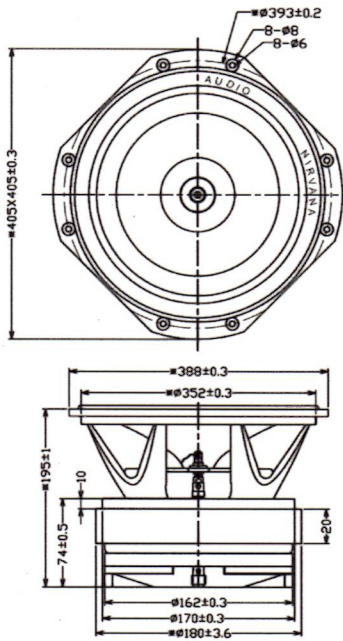

# Audio Nirvana Super 15" Coaxial



## Specifications & Thiele/Small Parameters

	Woofers	Tweeter
Impedance	8 Ohm	8 Ohm
Minimum Frequency Response	26 Hz	1200 Hz
Reproduction Frequency Response	F <sub>0</sub> ~11K	F <sub>0</sub> ~25K
S.P.L.	93.088 dB/W(m)	100 dB/W(m)
Rated Input	50 W	20 W
Music Power	80 W	30 W
Equivalent Diaphragm Radius	160mm	
Equivalent Mass	34.531 g	
Magnet Weight	1950 g	99 g
Net Weight	8000 g	300 g
F <sub>s</sub>	26.661 Hz	1200 Hz
R <sub>e</sub>	6.8 Ohm	6.8 Ohm
M <sub>ms</sub>	47.640 g	
BL	7.428 TM	
Q <sub>ts</sub>	0.767	
Q <sub>ms</sub>	3.493	
Q <sub>es</sub>	0.983	
V <sub>as</sub>	686.610 Ltr	
X <sub>max</sub>	1.0 mm	0.05mm
no	1.300 %	

	Woofers	Tweeter
Frame	Cast	Cast
Cone&Dome	Paper	Titanium
Surround	Cloth	Titanium
Damper	Conex	
VC DIA	KSV Φ49 0.25 CCAW	KSV Φ38 0.13 CCAW
Magnet	Φ180xΦ80x20 Y30	Φ37.5x12 N35

(Woofers)

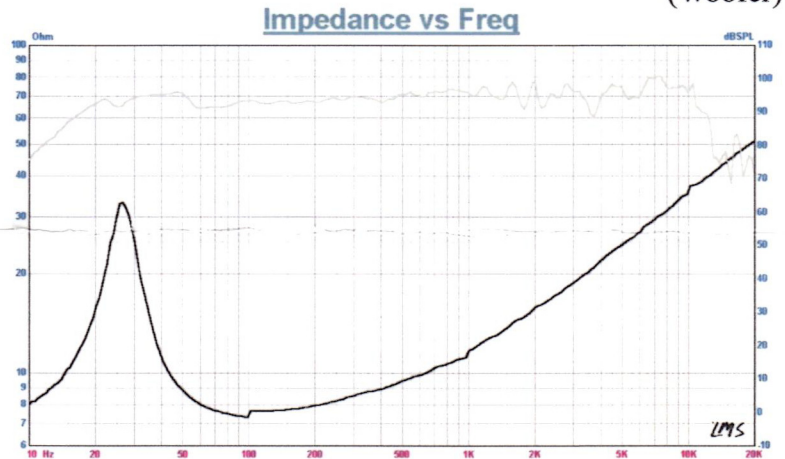

(Tweeter)

